

⇄ OUR OTHER PRODUCT RANGE ⇄



SINGLE GIRDER EOT CRANE
LOAD CAPACITY UP TO 15 TONS



DOUBLE GIRDER EOT CRANE
LOAD CAPACITY UP TO 200 TONS



UNDER SLUNG CRANE
LOAD CAPACITY UP TO 15 TONS



JIB CRANE
LOAD CAPACITY UP TO 2 TONS



GOLIATH CRANE
LOAD CAPACITY UP TO 200 TONS



MONORAIL CRANE
LOAD CAPACITY UP TO 10 TONS



**ELECTRIC WIRE
ROPE HOISTS**



SAHIL INDUSTRIES™
MANUFACTURERS OF CRANES AND HOISTS
AN ISO 9001:2000 CERTIFIED COMPANY

MANUFACTURING PLANT

B-88,89,90, Kagal-Hatkanangale Five Star M.I.D.C.,
Village-Halsawade, Tal.Karveer, Dist.Kolhapur 416 236
Tel.+91 231 2305176, Mobile. **08975813535, 09822254997**
Email.marketing@sahilcrane.com, sahilcranes@gmail.com
www.sahilcrane.com



SAHIL INDUSTRIES™
MANUFACTURER OF CRANES & HOISTS

AN ISO 9001-2008 CERTIFIED COMPANY



SAHIL INDUSTRIES™
MANUFACTURERS OF CRANES AND HOISTS
AN ISO 9001:2000 CERTIFIED COMPANY

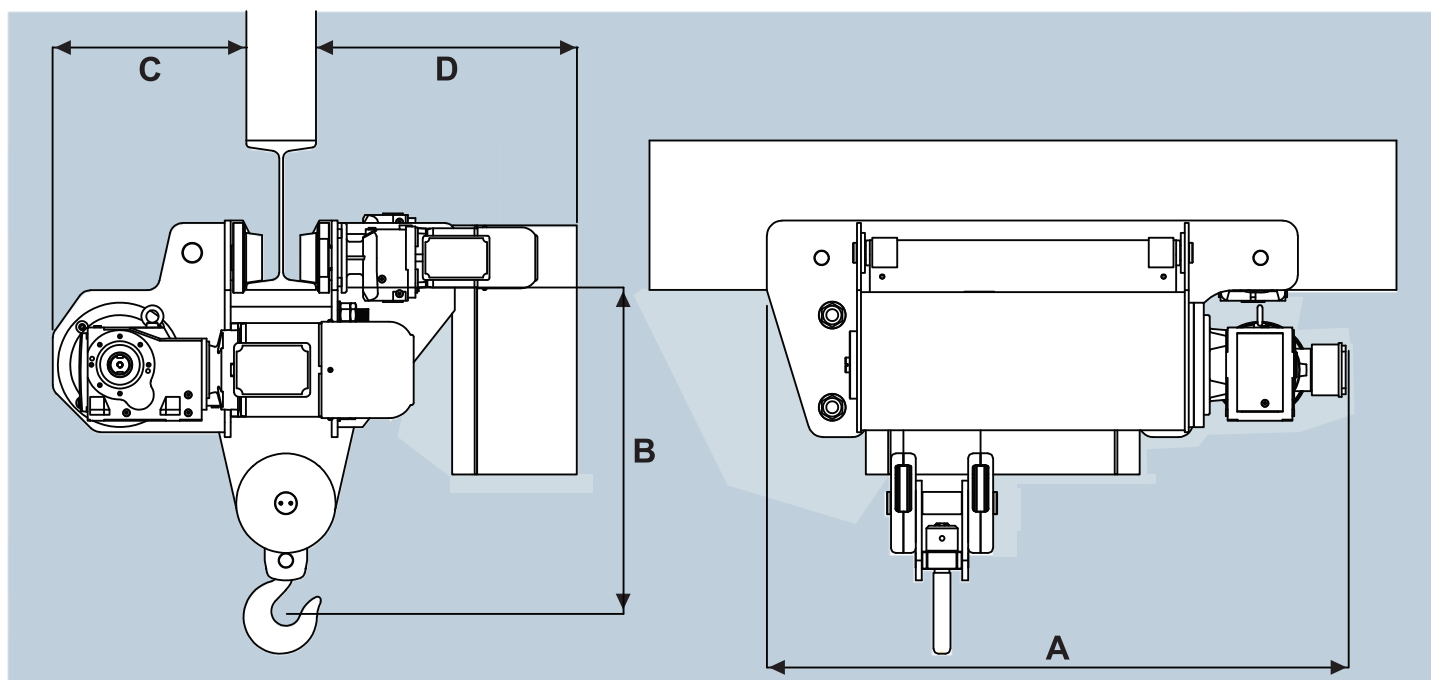

MODEL	052	104	204	304	504	604	7504	1004	1204	1504
SAFE WORKING LOAD (KG)	500	1000	2000	3000	5000	6000	7500	10000	12000	15000
LIFT (METERS)	8	5.5	8	8	8	8	8	8	8	8
NO. OF FALLS	2	4	4	4	4	4	4	4	4	4
ROPE DIAMETER IN MM (IWRC 6X36 CON.)	6	6	8	8	10	12	12	14	16	18
HOISTING SPEED (M/MIN)	3	3	3	3	4	3	3	3	3	3
HOISTING MOTOR (HP)	0.75	1	2	2.94	5.36	7.37	7.37	10	12.33	14.75
(KW)	0.55	0.75	1.5	2.2	4	5.5	5.5	7.5	9.2	11
CROSS TRAVEL SPEED (M/MIN)	15	15	15	15	15	15	15	15	15	15
CROSS TRAVEL MOTOR (HP)	0.16	0.16	0.24X2	0.24X2	0.33X2	0.33X2	0.5X2	0.5X2	0.73X2	1X2
(KW)	0.12	0.12	0.18X2	0.18X2	0.25X2	0.25X2	0.37X2	0.37X2	0.55X2	0.75X2

HOIST DIMENSION IN MM

A	770	920	1162	1176	1197	1452	1452	1491	1850	1850
B	500	550	650	650	800	950	950	1250	1350	1500
C	250	250	390	390	455	520	520	630	690	710
D	365	365	525	525	525	560	560	630	690	740
APPROXIMATE WEIGHT (KG)	190	225	334	345	490	560	691	1075	1340	1450

NOTE-

Please specify girder size at the time when you are placing order. Mentioned details are for standard models. Higher lifts & speeds are possible. Because of continuous improvement process in design and manufacturing overall dimensions may change without notice. All rights are reserve with Sahil Industries.



STANDARD FEATURES OF SAHIL ELECTRIC WIRE ROPE HOISTS

- COMPACT DESIGN
- LIGHT WEIGHT
- EASY TO MOVE MANUALLY
- LOW HEADROOM
- TROLLEY ADJUSTABLE FOR VARIOUS I-BEAM SIZES OR FABRICATED BOX
- BOTTOM HOOK BLOCK TESTED 200% OF FULL LOAD
- HARDENED AND GROUND GEAR BOX
- VFD FOR JERK-LESS AND SMOOTH OPERATIONS
- LOW VOLTAGE CONTROL SYSTEM OF 110V THAT MINIMIZES ELECTRICAL HAZARDS FOR THE OPERATOR
- POWER SAVING DESIGN
- ROPE GUIDE SPECIAL DESIGN FOR SMOOTH AND PROPER WINDING OF ROPE

EXTRA FEATURES (IF REQUIRED)

- LIFTS HIGHER THAN STANDARD MODELS
- SPECIAL TROLLEYS - LIKE SWIVEL ARTICULATED TYPE
- LIMIT SWITCHES - GRAVITY TYPE, CROSS TRAVEL LIMIT SWITCH, MECHANICAL LIMIT SWITCHES
- MICROSPEED FOR HOISTING AND CROSS TRAVEL-TROUGH VFD
- RADIO REMOTE CONTROL
- HEAT SHIELD
- CONTROL PANEL- OVER LOAD RELAY, SINGLE PHASE PREVENTER, MECHANICAL INTERLOCK CONTACTORS

NOTE - EXTRA FEATURES WILL BE APPLICABLE FOR ADDITIONAL COST.)

ELECTRIC WIRE ROPE HOISTS